

DO NOT SCALE OR USE FOR MEASUREMENT. REFER TO THE WORKSHOP FABRICATION DRAWING

# ATLAS FILTER MODEL

Filter service monorail (by contractor)  
c/w girder trolley, chain block, lifting chains etc

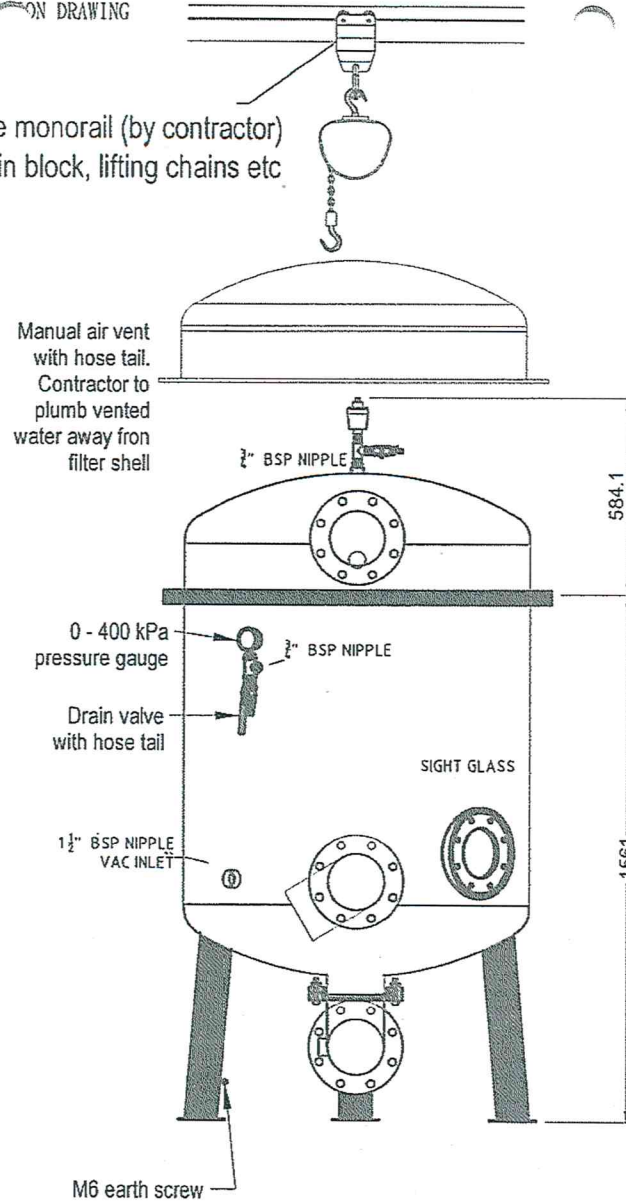
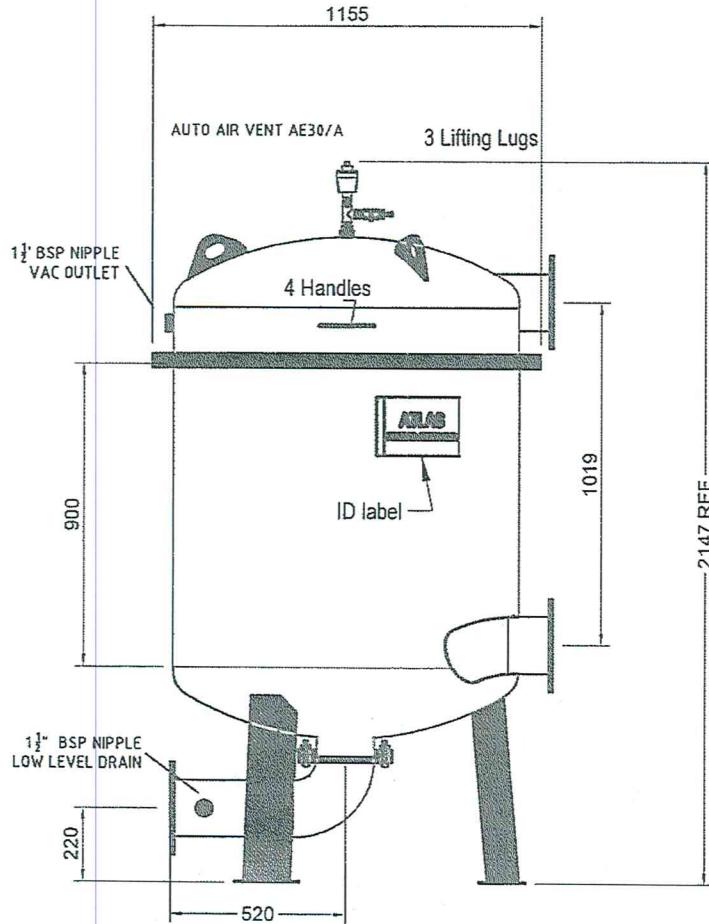

**CHADSON ENGINEERING**  
15 CRESSAL ROAD BALCATTA W.A 6021  
TEL. (08) 9344 3611 Fax. (08) 9344 5799

ALL EQUIPMENT, DESIGN AND APPLICATIONS SHOWN HEREIN ARE STRICTLY PRIVATE AND CONFIDENTIAL AND THE PROPERTY OF CHADSON ENGINEERING. NO USE OR DISCLOSURE THEREOF MAY BE MADE WITHOUT OUR PERMISSION IN WRITING

## TECHNICAL DETAILS

NOM Filter Area (m2)	20.0
Flow Range (m3/hr)	50 - 98
Required Back Wash (lt/Sec)	27
Number of Candles	85 x 5 Core
Effluent & Backwash size (mm)	150
Influent Nozzle (mm)	150
Flange Details	AS-2129 Table E
MIN Wash Water (m3)	3.5
Redox RS 400 (Min kgs)	11
Ceiling Height (mm) Manual Lift	2700
Shipping (m3)	2.7
Shipping (kgs)	620
Service Weight (kgs)	1790
Test Pressure (kPa)	350
Max Operating Pressure (kPa)	200
Filter Shell	Gr316 Stainless Steel
Vessel Class/Code	AS - 1210

### NOTES:

1. Backwash pipe can be rotated to a position that suits specific project requirements. Standard location is at 0° rear. Specify angle required i.e., 45°, 180° front etc. See Plan View.
2. Dimensions subject to change without notice.
3. All dimensions subject to shop details and/or specific project requirements.
4. Face plumbing, valves etc by installing contractor.
5. All material (UNO) To be grade 316L S/S. Fully Welded.

### SERVICE CLEARANCE NOTE

Service crane drawn is for multiple filter installations enabling the lid/pressure plate (of the filter being serviced) to be moved above and over the other filters in the filter bank.

Service Height Detail ;

No Overhead Crane - Lift 150mm and move away from the tank  
Overhead crane - Lift min. of 600mm for filter service and or clearance of surrounding tanks.

CLIENT				
TITLE				
PCT-200				
DRAWN	DATE	DRAWING No.	REV	SHEET SIZE
BNC	OCT18	-		A3
CKD:	APPD:	SCALE		